



Constellation[®].2

v6 SATA Product Manual

Standard models

ST91000640NS
ST9500620NS
ST9250610NS

Self-Encrypting Drive Models

ST91000641NS
ST9500621NS
ST9250611NS

SED FIPS 140-2 Models

ST91000642NS
ST9500622NS
ST9250612NS

100545983, Rev. G
April 2016

Document Revision History

| Revision | Date | Sheets affected or comments |
|----------|----------|-----------------------------|
| Rev. A | 06/16/10 | Initial release. |
| Rev. B | 10/12/10 | fc, 2, 15-19, 23-24 & 31. |
| Rev. C | 02/14/11 | 5, 8, 10-12, 14 & 27. |
| Rev. D | 03/15/11 | 13, 25, 29-30 & 33-34. |
| Rev. E | 04/28/11 | fc, 2 & 5. |
| Rev. F | 02/27/12 | fc, 2, 5, 28-31 & 35. |
| Rev. G | 04/08/16 | 5, 9, 11, 24 & 27 |

© 2016 Seagate Technology LLC. All rights reserved.

Publication number: 100545983, Rev. G April 2016

Seagate, Seagate Technology and the Spiral logo are registered trademarks of Seagate Technology LLC in the United States and/or other countries. Raid Rebuild and SeaTools are either trademarks or registered trademarks of Seagate Technology LLC or one of its affiliated companies in the United States and/or other countries. The FIPS logo is a certification mark of NIST, which does not imply product endorsement by NIST, the U.S., or Canadian governments. All other trademarks or registered trademarks are the property of their respective owners.

No part of this publication may be reproduced in any form without written permission of Seagate Technology LLC.

Call 877-PUB-TEK1 (877-782-8351) to request permission.

When referring to drive capacity, one gigabyte, or GB, equals one billion bytes and one terabyte, or TB, equals one trillion bytes. Your computer's operating system may use a different standard of measurement and report a lower capacity. In addition, some of the listed capacity is used for formatting and other functions, and thus will not be available for data storage. Actual quantities will vary based on various factors, including file size, file format, features and application software. Actual data rates may vary depending on operating environment and other factors. The export or re-export of hardware or software containing encryption may be regulated by the U.S. Department of Commerce, Bureau of Industry and Security (for more information, visit www.bis.doc.gov), and controlled for import and use outside of the U.S. Seagate reserves the right to change, without notice, product offerings or specifications.

Contents

| | | |
|------------|---------------------------------------------------------------------------|-----------|
| 1.0 | Introduction | 6 |
| 1.1 | About the Serial ATA interface | 8 |
| 2.0 | Drive specifications | 9 |
| 2.1 | Specification summary tables | 9 |
| 2.2 | Formatted capacity | 11 |
| 2.2.1 | LBA mode | 11 |
| 2.3 | Default logical geometry | 11 |
| 2.4 | Recording and interface technology | 12 |
| 2.5 | Physical characteristics | 12 |
| 2.6 | Seek time | 12 |
| 2.7 | Start/stop times | 13 |
| 2.8 | Power specifications | 13 |
| 2.8.1 | Power consumption | 13 |
| 2.8.2 | Conducted noise | 18 |
| 2.8.3 | Voltage tolerance | 18 |
| 2.8.4 | Power-management modes | 19 |
| 2.9 | Environmental limits | 21 |
| 2.9.1 | Temperature | 21 |
| 2.9.2 | Relative humidity | 21 |
| 2.9.3 | Effective altitude (sea level) | 22 |
| 2.9.4 | Shock | 22 |
| 2.9.5 | Vibration | 22 |
| 2.10 | Acoustics | 23 |
| 2.11 | Electromagnetic immunity | 23 |
| 2.12 | Reliability | 24 |
| 2.12.1 | Annualized Failure Rate (AFR) and Mean Time Between Failures (MTBF) | 24 |
| 2.13 | Agency certification | 24 |
| 2.13.1 | Safety certification | 24 |
| 2.13.2 | Electromagnetic compatibility | 24 |
| 2.13.3 | FCC verification | 25 |
| 2.14 | Environmental protection | 26 |
| 2.14.1 | European Union Restriction of Hazardous Substances (RoHS) Directive | 26 |
| 2.14.2 | China Restriction of Hazardous Substances (RoHS) Directive | 26 |
| 2.15 | Corrosive environment | 26 |
| 2.16 | Reference documents | 27 |
| 2.17 | Product warranty | 27 |
| 3.0 | Configuring and mounting the drive | 28 |
| 3.1 | Handling and static-discharge precautions | 28 |
| 3.2 | Configuring the drive | 29 |
| 3.3 | Serial ATA cables and connectors | 29 |
| 3.4 | Drive mounting | 29 |
| 3.4.1 | Mechanical specifications | 30 |
| 3.5 | Cooling | 31 |
| 4.0 | About FIPS | 32 |
| 5.0 | About self-encrypting drives | 33 |
| 5.1 | Data encryption | 33 |
| 5.2 | Controlled access | 33 |
| 5.2.1 | Admin SP | 33 |
| 5.2.2 | Locking SP | 33 |
| 5.2.3 | Default password | 34 |
| 5.3 | Random number generator (RNG) | 34 |

| | | |
|------------|--------------------------------------------------------|-----------|
| 5.4 | Drive locking | 34 |
| 5.5 | Data bands | 34 |
| 5.6 | Cryptographic erase | 34 |
| 5.7 | Authenticated firmware download | 34 |
| 5.8 | Power requirements | 35 |
| 5.9 | Supported commands | 35 |
| 5.10 | RevertSP | 35 |
| 5.11 | ATA Security Erase Unit Command on SED drives | 35 |
| 5.12 | Sanitize Device - CRYPTO SCRAMBLE EXT | 35 |
| 6.0 | Serial ATA (SATA) interface | 36 |
| 6.1 | Hot-Plug compatibility | 36 |
| 6.2 | Serial ATA device plug connector pin definitions | 37 |
| 6.3 | Supported ATA commands | 38 |
| 6.3.1 | Identify Device command | 40 |
| 6.3.2 | Set Features command | 44 |
| 6.3.3 | S.M.A.R.T. commands | 45 |

List of Figures

| | | |
|-----------|----------------------------------------------------------------------------|----|
| Figure 1. | Typical 5V/12V startup and operation current profile for 1TB models | 17 |
| Figure 2. | Typical 5V/12V startup and operation current profile for 500GB models..... | 17 |
| Figure 3. | Typical 5V/12V startup and operation current profile for 250GB models..... | 18 |
| Figure 4. | Location of the HDA temperature check point | 21 |
| Figure 5. | Attaching SATA cabling | 29 |
| Figure 6. | Mounting dimensions—top, side and end view | 30 |
| Figure 7. | Air flow | 31 |
| Figure 8. | Example of FIPS tamper evidence labels..... | 32 |

Seagate® Technology Support Services

For information regarding online support and services, visit: <http://www.seagate.com/contacts/>

For information regarding Warranty Support, visit: <http://www.seagate.com/support/warranty-and-replacements/>

For information regarding data recovery services, visit: <http://www.seagate.com/services-software/seagate-recovery-services/recover/>

For Seagate OEM, Distribution partner and reseller portals, visit: <http://www.seagate.com/partners>

1.0 Introduction

This manual describes the functional, mechanical and interface specifications for the following Seagate Constellation®.2 Serial ATA model drives:

| Model Number | Self-Encrypting Drive (SED) | FIPS 140-2 Level 2 |
|--------------|-----------------------------|--------------------|
| ST91000640NS | No | No |
| ST91000641NS | Yes | No |
| ST91000642NS | Yes | Yes |
| ST9500620NS | No | No |
| ST9500621NS | Yes | No |
| ST9500622NS | Yes | Yes |
| ST9250610NS | No | No |
| ST9250611NS | Yes | No |
| ST9250612NS | Yes | Yes |

Note. Previous generations of Seagate Self-Encrypting Drive models were called Full Disk Encryption (FDE) models before a differentiation between drive-based encryption and other forms of encryption was necessary.

Note. The Self-Encrypting Drive models indicated on the cover of this product manual have provisions for “Security of Data at Rest” based on the standards defined by the Trusted Computing Group (see www.trustedcomputinggroup.org).

For more information on FIPS 140-2 Level 2 certification see See Section 4.0 on page 32.

These drives provide the following key features:

- 7200 RPM spindle speed.
- High instantaneous (burst) data-transfer rates (up to 600MB/s).
- Perpendicular recording technology provides the drives with increased areal density.
- State-of-the-art cache and on-the-fly error-correction algorithms.
- Native Command Queuing with command ordering to increase performance in demanding applications.
- Full-track multiple-sector transfer capability without local processor intervention.
- Quiet operation.
- SeaTools diagnostic software performs a drive self-test that eliminates unnecessary drive returns.
- Support for S.M.A.R.T. drive monitoring and reporting.
- Supports latching SATA cables and connectors.
- Worldwide Name (WWN) capability uniquely identifies the drive.

Constellation.2 Serial ATA Self-Encrypting Drive models have the following additional features:

- Automatic data encryption/decryption
- Controlled access
- Random number generator
- Drive locking
- 16 independent data bands
- Cryptographic erase of user data for a drive that will be repurposed or scrapped
- Authenticated firmware download

Note. There is no significant performance difference between Self-Encrypting Drive and standard (non-Self-Encrypting Drive) models.

1.1 About the Serial ATA interface

The Serial ATA interface provides several advantages over the traditional (parallel) ATA interface. The primary advantages include:

- Easy installation and configuration with true plug-and-play connectivity. It is not necessary to set any jumpers or other configuration options.
- Thinner and more flexible cabling for improved enclosure airflow and ease of installation.
- Scalability to higher performance levels.

In addition, Serial ATA makes the transition from parallel ATA easy by providing legacy software support. Serial ATA was designed to allow you to install a Serial ATA host adapter and Serial ATA disc drive in your current system and expect all of your existing applications to work as normal.

The Serial ATA interface connects each disc drive in a point-to-point configuration with the Serial ATA host adapter. There is no master/slave relationship with Serial ATA devices like there is with parallel ATA. If two drives are attached on one Serial ATA host adapter, the host operating system views the two devices as if they were both “masters” on two separate ports. This essentially means both drives behave as if they are Device 0 (master) devices.

Note. The host adapter may, optionally, emulate a master/slave environment to host software where two devices on separate Serial ATA ports are represented to host software as a Device 0 (master) and Device 1 (slave) accessed at the same set of host bus addresses. A host adapter that emulates a master/slave environment manages two sets of shadow registers. This is not a typical Serial ATA environment.

The Serial ATA host adapter and drive share the function of emulating parallel ATA device behavior to provide backward compatibility with existing host systems and software. The Command and Control Block registers, PIO and DMA data transfers, resets, and interrupts are all emulated.

The Serial ATA host adapter contains a set of registers that shadow the contents of the traditional device registers, referred to as the Shadow Register Block. All Serial ATA devices behave like Device 0 devices. For additional information about how Serial ATA emulates parallel ATA, refer to the “Serial ATA: High Speed Serialized AT Attachment” specification. The specification can be downloaded from www.serialata.org.

2.0 Drive specifications

Unless otherwise noted, all specifications are measured under ambient conditions, at 25°C, and nominal power. For convenience, the phrases *the drive* and *this drive* are used throughout this manual to indicate the following drive models:

Unless otherwise stated, the information in this manual applies to standard and Self-Encrypting Drive models

| Model Number | Self-Encrypting Drive (SED) | FIPS 140-2 Level 2 |
|--------------|-----------------------------|--------------------|
| ST91000640NS | No | No |
| ST91000641NS | Yes | No |
| ST91000642NS | Yes | Yes |
| ST9500620NS | No | No |
| ST9500621NS | Yes | No |
| ST9500622NS | Yes | Yes |
| ST9250610NS | No | No |
| ST9250611NS | Yes | No |
| ST9250612NS | Yes | Yes |

Product data communicated in this manual is specific only to the model numbers listed in this manual. The data listed in this manual may not be predictive of future generation specifications or requirements. If you are designing a system which will use one of the models listed or future generation products and need further assistance, please contact your Field Applications Engineer (FAE) or our global support services group (“Seagate® Technology Support Services” on page 5).

2.1 Specification summary tables

The specifications listed in the following tables are for quick reference. For details on specification measurement or definition, see the appropriate section of this manual.

Table 1: Drive specifications summary for 1TB, 500 and 250 GB models

| Drive specification | ST91000640NS ST91000641NS ST91000642NS | ST9500620NS ST9500621NS ST9500622NS | ST9250610NS ST9250611NS ST9250612NS |
|-------------------------------------------------------|-----------------------------------------------------------------|-------------------------------------------|-------------------------------------------|
| Formatted GB (512 bytes/sector)* | 1000 | 500 | 250 |
| Guaranteed sectors | 1,953,525,168 | 976,773,168 | 488,397,168 |
| Heads | 8 | 4 | 2 |
| Discs | 4 | 2 | 1 |
| Bytes per sector | 512 | | |
| Default sectors per track | 63 | | |
| Default read/write heads | 16 | | |
| Default cylinders | 16,383 | | |
| Recording density, KBPI (Kb/in max) | 1544 | | |
| Track density, KTPI (Ktracks/in avg.) | 270 | | |
| Areal density, (Gb/in ² avg) | 417 | | |
| Spindle speed (RPM) | 7200 | | |
| Internal data transfer rate (Mb/s max) | 1304 | | |
| Sustained data transfer rate OD (MB/s max) | 115 | | |
| I/O data-transfer rate (MB/s max) | 600 | | |
| ATA data-transfer modes supported | PIO modes 0–4 Multiword DMA modes 0–2 Ultra DMA modes 0–6 | | |
| Cache buffer | 64 MB | | |
| Weight: (maximum) | 200 g (0.441 lb) | 183 g (0.403 lb) | 179 g (0.395 lb) |
| Average latency | 4.16 ms | | |
| Power-on to ready (sec max) | 20 sec | | |
| Standby to ready (sec max) | 13 sec | | |
| Track-to-track seek time (ms typical) | 0.23 read 0.44 write | | |
| Average seek, read (ms typical) | 7.5 | | |
| Average seek, write (ms typical) | 8.5 | | |
| Startup current (typical) 12V (peak) | 2.0 amps | | |
| Voltage tolerance (including noise) | 5V ±5% 12V ±5% | | |
| Ambient temperature | 5° to 60°C (operating) –40° to 70°C (nonoperating) | | |
| Temperature gradient (°C per hour max) | 20°C (operating) 20°C (nonoperating) | | |
| Relative humidity | 5% to 95% (operating) 5% to 95% (nonoperating) | | |
| Relative humidity gradient | 20% per hour max | | |
| Wet bulb temperature (°C max) | 28°C | | |
| Altitude, operating | –60.96 m to 3,048 m (–200 ft. to 10,000+ ft.) | | |
| Altitude, nonoperating (below mean sea level, max) | –60.96 m to 12,192 m (–200 ft. to 40,000+ ft.) | | |
| Operational Shock (max at 2 ms) | Read 70 Gs / Write 40 Gs | | |
| Non-Operational Shock (max at 2 ms) | 400 Gs | | |
| Vibration, operating | 5–500 Hz: 0.5 Gs | | |
| Vibration, nonoperating | 5–500 Hz: 3.0 Gs | | |

| | | | |
|----------------------------------------------------------------------|-----------------------------------------------------------------------------------------------------------------------------------------------------------------------------------------------------------------------------------------------------------------------------------------------------------------------------------------------------------------------------------------------------------------------------------------------------------------------------------------------------------------------------|-------------------------------------------|-------------------------------------------|
| Drive specification | ST91000640NS ST91000641NS ST91000642NS | ST9500620NS ST9500621NS ST9500622NS | ST9250610NS ST9250611NS ST9250612NS |
| Drive acoustics, sound power (bels) | | | |
| Active | 2.8 (typical) | | |
| Idle** | 2.2 (typical) | | |
| Nonrecoverable read errors | 1 sector per 10 ¹⁵ bits read | | |
| Annualized Failure Rate (AFR) | 0.62% | | |
| Warranty | To determine the warranty for a specific drive, use a web browser to access the following web page: http://www.seagate.com/www/en-us/support/warranty_&_returns_assistance From this page, click on the "Is my Drive under Warranty" link. You will be asked to provide the drive serial number, model number (or part number) and country of purchase. The system will display the warranty information for your drive. | | |
| Load/Unload cycles | 300,000 (25°C, 50% rel. humidity) (600,000 design life testing) | | |
| Supports Hotplug operation per Serial ATA Revision 2.6 specification | Yes | | |

*One GB equals one billion bytes when referring to hard drive capacity. Accessible capacity may vary depending on operating environment and formatting.

**During periods of drive idle, some offline activity may occur according to the S.M.A.R.T. specification, which may increase acoustic and power to operational levels.

2.2 Formatted capacity

| Model | Formatted capacity* | Guaranteed sectors | Bytes per sector |
|----------------------------------------------|---------------------|--------------------|------------------|
| ST91000640NS ST91000641NS ST91000642NS | 1000 GB | 1,953,525,168 | 512 |
| ST9500620NS ST9500621NS ST9500622NS | 500 GB | 976,773,168 | |
| ST9250610NS ST9250611NS ST9250612NS | 250 GB | 488,397,168 | |

*One GB equals one billion bytes when referring to hard drive capacity. Accessible capacity may vary depending on operating environment and formatting.

2.2.1 LBA mode

When addressing these drives in LBA mode, all blocks (sectors) are consecutively numbered from 0 to $n-1$, where n is the number of guaranteed sectors as defined above.

See Section 6.3.1, "Identify Device command" (words 60-61 and 100-103) for additional information about 48-bit addressing support of drives with capacities over 137 GB.

2.3 Default logical geometry

| Cylinders | Read/write heads | Sectors per track |
|-----------|------------------|-------------------|
| 16,383 | 16 | 63 |

LBA mode

When addressing these drives in LBA mode, all blocks (sectors) are consecutively numbered from 0 to $n-1$, where n is the number of guaranteed sectors as defined above.

2.4 Recording and interface technology

| | All models |
|-----------------------------------------|-------------------|
| Interface | Serial ATA (SATA) |
| Recording method | Perpendicular |
| Recording density, KBPI (Kb/in max) | 1544 |
| Track density, KTPI (Ktracks/in avg) | 270 |
| Areal density (Gb/in ² avg) | 417 |
| Spindle speed (RPM) (± 0.2%) | 7200 |
| Internal data transfer rate (Mb/s max) | 1304 |
| Sustained data transfer rate (MB/s max) | 115 |
| I/O data-transfer rate (MB/s max) | 600 |

2.5 Physical characteristics

| | |
|-------------------|-------------------|
| Weight: (maximum) | |
| 1TB models | 200 g (0.441 lb) |
| 500GB models | 183 g (0.403 lb) |
| 250GB models | 179 g (0.395 lb) |
| Cache buffer | 64 MB (65,536 KB) |

Note. Refer to Figure 6, page 30 for detailed mounting configuration dimensions.

2.6 Seek time

Seek measurements are taken with nominal power at 25°C ambient temperature. All times are measured using drive diagnostics. The specifications in the table below are defined as follows:

- Track-to-track seek time is an average of all possible single-track seeks in both directions.
- Average seek time is a true statistical random average of at least 5,000 measurements of seeks between random tracks, less overhead.

| *Typical seek times (ms) | Read | Write |
|--------------------------|-------|-------|
| Track-to-track | 0.23 | 0.44 |
| Average | 7.5 | 8.5 |
| Full Stroke | 17.06 | 18.08 |
| Average latency: | 4.16 | |

*Measured in performance mode.

Note. These drives are designed to consistently meet the seek times represented in this manual. Physical seeks, regardless of mode (such as track-to-track and average), are expected to meet the noted values. However, due to the manner in which these drives are formatted, benchmark tests that include command overhead or measure logical seeks may produce results that vary from these specifications.

2.7 Start/stop times

| | |
|-----------------------------|----------|
| Power-on to Ready (sec) | 20 (max) |
| Standby to Ready (sec) | 13 (max) |
| Ready to spindle stop (sec) | 20 (max) |

2.8 Power specifications

The drive receives DC power (+5V or +12V) through a native SATA power connector. See Figure 5, page 29 on page 29.

2.8.1 Power consumption

Power requirements for the drives are listed in the table on page 9. Typical power measurements are based on an average of drives tested, under nominal conditions, using 5.0V and 12.0V input voltage at 25°C ambient temperature.

- **Spinup power**

Spinup power is measured from the time of power-on to the time that the drive spindle reaches operating speed.

- **Standby mode**

During Standby mode, the drive accepts commands, but the drive is not spinning, and the servo and read/write electronics are in power-down mode.

The standard drive models and the SED drive models have identical hardware, however the security and encryption portion of the drive controller ASIC is enabled and functional in the SED models. This represents a small additional drain on the 5V supply of about 30mA and a commensurate increase of about 150mW in power consumption. There is no additional drain on the 12V supply.

Table 2: 1000GB drive (Standard & SED model) DC power requirements

| Parameter | ST91000640NS (3.0GB) | | | ST91000640NS (6.0GB) | | |
|--------------------------------------------|-------------------------|-------|---------|-------------------------|-------|---------|
| | +5 V | +12 V | Power | +5 V | +12 V | Power |
| Regulation | +/-5% | | (watts) | +/-5% | | (watts) |
| Average Idle Current | 0.22 | 0.15 | 2.92 | 0.23 | 0.15 | 2.95 |
| Advanced Idle Current | | | | | | |
| Idle1 | 0.22 | 0.15 | 2.91 | 0.23 | 0.15 | 2.96 |
| Idle2 | 0.15 | 0.13 | 2.28 | 0.16 | 0.13 | 2.32 |
| Idle3 | 0.15 | 0.09 | 1.84 | 0.16 | 0.09 | 1.89 |
| Standby | 0.14 | 0.04 | 1.20 | 0.14 | 0.04 | 1.23 |
| Average Sleep Current | 0.14 | 0.04 | 1.17 | 0.14 | 0.04 | 1.21 |
| Maximum Start Current: | | | | | | |
| DC (Peak DC) | 0.51 | 0.85 | 12.70 | 0.51 | 0.85 | 12.73 |
| AC (Peak AC) | 0.70 | 1.20 | 17.93 | 0.74 | 1.22 | 18.35 |
| Delayed Motor Start (DC max) | 0.14 | 0.04 | 1.20 | 0.14 | 0.04 | 1.22 |
| Peak Operating Current (random read): | | | | | | |
| Typical DC | 0.30 | 0.32 | 5.39 | 0.31 | 0.32 | 5.43 |
| Maximum DC | 0.30 | 0.33 | 5.45 | 0.32 | 0.33 | 5.52 |
| Maximum DC (peak) | 1.04 | 0.88 | 15.76 | 1.02 | 0.90 | 15.90 |
| Peak Operating Current (random write): | | | | | | |
| Typical DC | 0.38 | 0.27 | 5.20 | 0.39 | 0.27 | 5.25 |
| Maximum DC | 0.39 | 0.27 | 5.23 | 0.40 | 0.28 | 5.32 |
| Maximum DC (peak) | 0.94 | 0.88 | 15.26 | 0.96 | 0.90 | 15.60 |
| Peak operating current (sequential read): | | | | | | |
| Typical DC | 0.61 | 0.18 | 5.17 | 0.62 | 0.18 | 5.21 |
| Maximum DC | 0.62 | 0.18 | 5.24 | 0.64 | 0.18 | 5.31 |
| Maximum DC (peak) | 0.82 | 0.34 | 8.18 | 0.86 | 0.34 | 8.38 |
| Peak operating current (sequential write): | | | | | | |
| Typical DC | 0.77 | 0.18 | 5.96 | 0.78 | 0.18 | 6.00 |
| Maximum DC | 0.78 | 0.18 | 6.04 | 0.81 | 0.18 | 6.16 |
| Maximum DC (peak) | 0.98 | 0.34 | 8.98 | 0.98 | 0.38 | 9.46 |

*During periods of drive idle, some offline activity may occur according to the S.M.A.R.T. specification, which may increase acoustic and power to operational levels.

500GB drive (Standard & SED model) DC power requirements

| Parameter | ST9500620NS (3.0GB) | | | ST9500620NS (6.0GB) | | |
|--------------------------------------------|------------------------|-------|---------|------------------------|-------|---------|
| | +5 V | +12 V | Power | +5 V | +12 V | Power |
| Regulation | +/-5% | | (watts) | +/-5% | | (watts) |
| Average Idle Current | 0.22 | 0.11 | 2.40 | 0.23 | 0.11 | 2.44 |
| Advanced Idle Current | | | | | | |
| Idle1 | 0.22 | 0.11 | 2.40 | 0.23 | 0.11 | 2.43 |
| Idle2 | 0.16 | 0.09 | 1.88 | 0.16 | 0.09 | 1.93 |
| Idle3 | 0.16 | 0.07 | 1.64 | 0.16 | 0.07 | 1.67 |
| Standby | 0.14 | 0.04 | 1.17 | 0.15 | 0.04 | 1.22 |
| Average Sleep Current | 0.14 | 0.04 | 1.17 | 0.15 | 0.04 | 1.20 |
| Maximum Start Current: | | | | | | |
| DC (Peak DC) | 0.47 | 0.80 | 11.93 | 0.47 | 0.80 | 11.98 |
| AC (Peak AC) | 0.69 | 1.18 | 17.66 | 0.63 | 1.19 | 17.38 |
| Delayed Motor Start (DC max) | 0.14 | 0.04 | 1.19 | 0.15 | 0.04 | 1.23 |
| Peak Operating Current (random read): | | | | | | |
| Typical DC | 0.29 | 0.27 | 4.69 | 0.29 | 0.27 | 4.73 |
| Maximum DC | 0.29 | 0.27 | 4.74 | 0.30 | 0.28 | 4.79 |
| Maximum DC (peak) | 0.96 | 0.82 | 14.64 | 1.00 | 0.86 | 15.32 |
| Peak Operating Current (random write): | | | | | | |
| Typical DC | 0.37 | 0.23 | 4.55 | 0.37 | 0.23 | 4.59 |
| Maximum DC | 0.37 | 0.23 | 4.61 | 0.38 | 0.23 | 4.65 |
| Maximum DC (peak) | 0.90 | 0.86 | 14.82 | 0.92 | 0.84 | 14.68 |
| Peak operating current (sequential read): | | | | | | |
| Typical DC | 0.58 | 0.13 | 4.46 | 0.59 | 0.13 | 4.49 |
| Maximum DC | 0.59 | 0.13 | 4.54 | 0.60 | 0.13 | 4.55 |
| Maximum DC (peak) | 0.76 | 0.30 | 7.40 | 0.80 | 0.30 | 7.60 |
| Peak operating current (sequential write): | | | | | | |
| Typical DC | 0.75 | 0.13 | 5.28 | 0.75 | 0.13 | 5.31 |
| Maximum DC | 0.77 | 0.13 | 5.40 | 0.77 | 0.13 | 5.40 |
| Maximum DC (peak) | 0.92 | 0.30 | 8.20 | 0.98 | 0.28 | 8.26 |

*During periods of drive idle, some offline activity may occur according to the S.M.A.R.T. specification, which may increase acoustic and power to operational levels.

250GB drive (Standard & SED model) DC power requirements

| Parameter | ST9250610NS (3.0GB) | | | ST9250610NS (6.0GB) | | |
|--------------------------------------------|------------------------|-------|---------|------------------------|-------|---------|
| | +5 V | +12 V | Power | +5 V | +12 V | Power |
| Regulation | +/-5% | | (watts) | +/-5% | | (watts) |
| Average Idle Current | 0.22 | 0.09 | 2.23 | 0.23 | 0.09 | 2.25 |
| Advanced Idle Current | | | | | | |
| Idle1 | 0.22 | 0.09 | 2.22 | 0.22 | 0.09 | 2.24 |
| Idle2 | 0.16 | 0.08 | 1.81 | 0.17 | 0.08 | 1.82 |
| Idle3 | 0.16 | 0.07 | 1.61 | 0.16 | 0.07 | 1.63 |
| Standby | 0.14 | 0.04 | 1.20 | 0.15 | 0.04 | 1.24 |
| Average Sleep Current | 0.14 | 0.04 | 1.20 | 0.15 | 0.04 | 1.22 |
| Maximum Start Current: | | | | | | |
| DC (Peak DC) | 0.51 | 0.78 | 11.96 | 0.52 | 0.78 | 11.92 |
| AC (Peak AC) | 0.64 | 1.14 | 16.93 | 0.60 | 1.14 | 16.70 |
| Delayed Motor Start (DC max) | 0.15 | 0.04 | 1.24 | 0.16 | 0.04 | 1.29 |
| Peak Operating Current (random read): | | | | | | |
| Typical DC | 0.29 | 0.26 | 4.54 | 0.30 | 0.26 | 4.61 |
| Maximum DC | 0.29 | 0.26 | 4.63 | 0.30 | 0.27 | 4.71 |
| Maximum DC (peak) | 0.96 | 0.84 | 14.88 | 0.96 | 0.82 | 14.64 |
| Peak Operating Current (random write): | | | | | | |
| Typical DC | 0.39 | 0.21 | 4.48 | 0.39 | 0.22 | 4.55 |
| Maximum DC | 0.39 | 0.22 | 4.55 | 0.40 | 0.22 | 4.64 |
| Maximum DC (peak) | 0.82 | 0.84 | 14.18 | 0.84 | 0.80 | 13.80 |
| Peak operating current (sequential read): | | | | | | |
| Typical DC | 0.57 | 0.11 | 4.17 | 0.58 | 0.11 | 4.22 |
| Maximum DC | 0.58 | 0.11 | 4.25 | 0.59 | 0.11 | 4.32 |
| Maximum DC (peak) | 0.74 | 0.28 | 7.06 | 0.78 | 0.26 | 7.02 |
| Peak operating current (sequential write): | | | | | | |
| Typical DC | 0.70 | 0.11 | 4.81 | 0.70 | 0.11 | 4.86 |
| Maximum DC | 0.71 | 0.11 | 4.89 | 0.72 | 0.11 | 4.95 |
| Maximum DC (peak) | 0.86 | 0.26 | 7.42 | 0.90 | 0.26 | 7.62 |

*During periods of drive idle, some offline activity may occur according to the S.M.A.R.T. specification, which may increase acoustic and power to operational levels.

2.8.1.1 Typical current profiles

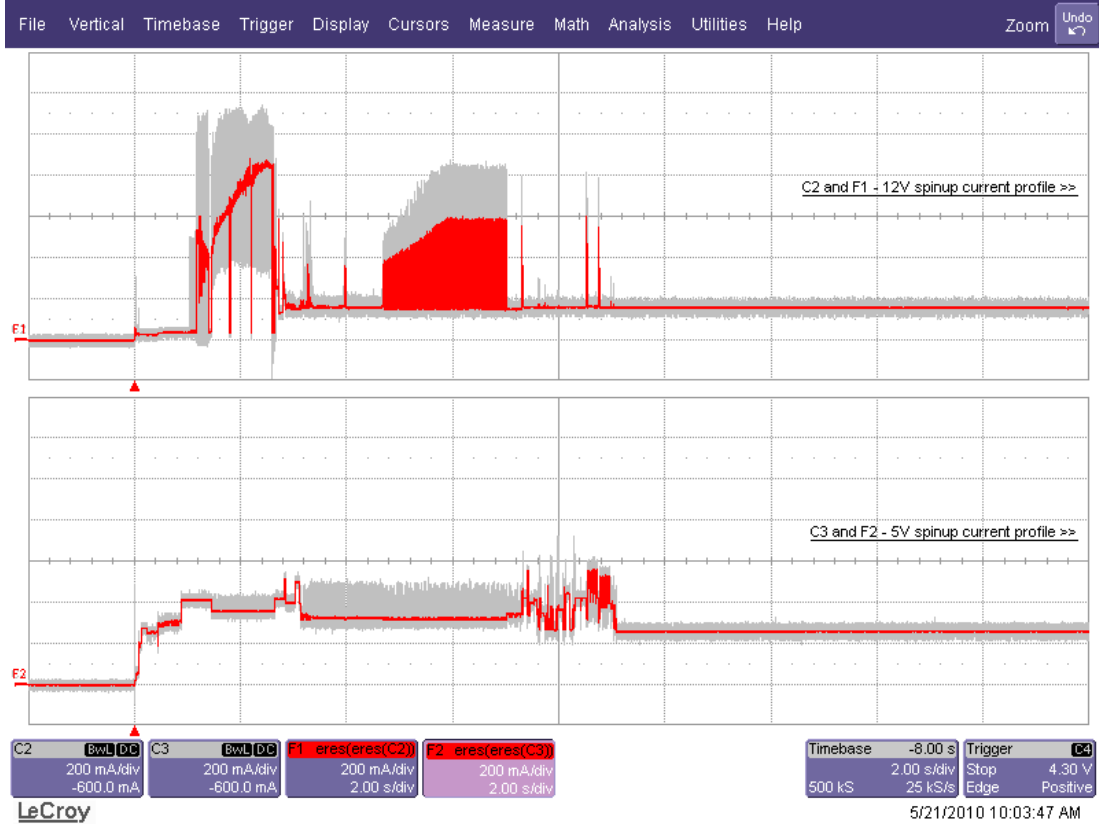

Figure 1. Typical 5V/12V startup and operation current profile for 1TB models

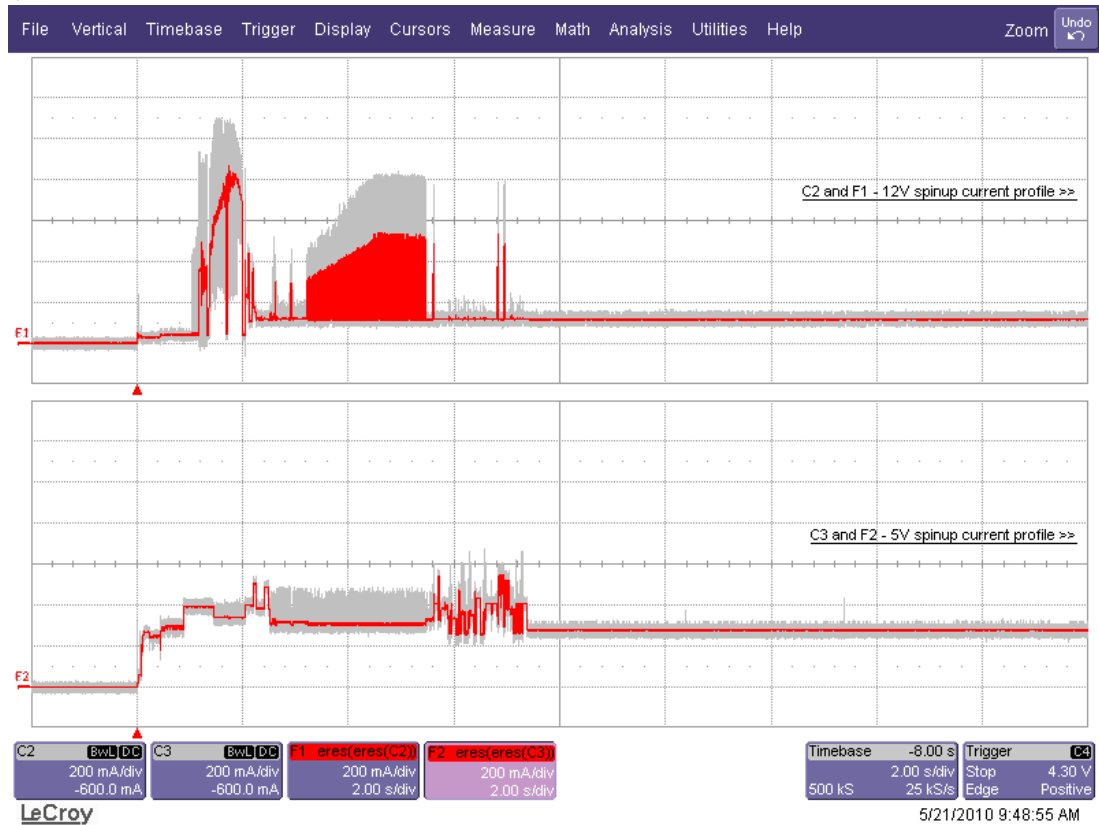

Figure 2. Typical 5V/12V startup and operation current profile for 500GB models

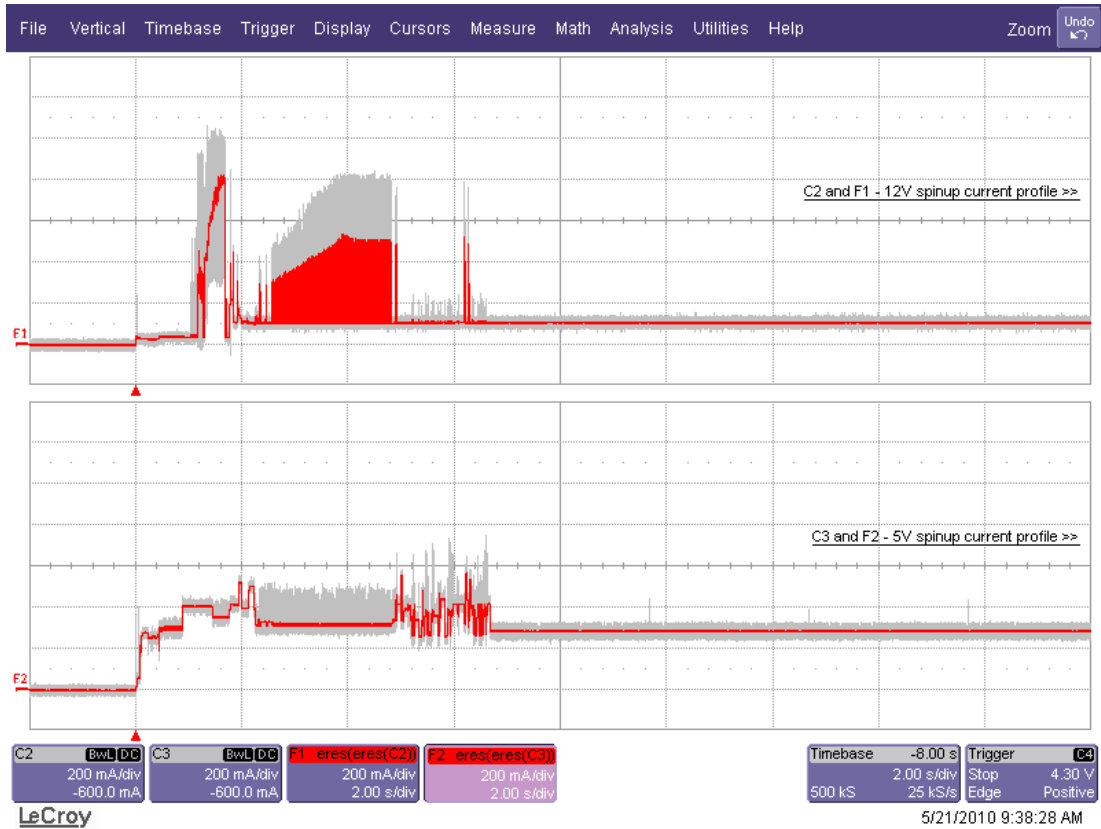

Figure 3. Typical 5V/12V startup and operation current profile for 250GB models

2.8.2 Conducted noise

Noise is specified as a periodic and random distribution of frequencies covering a defined frequency. Maximum allowed noise values given below are peak-to-peak measurements and apply at the drive power connector.

- +5v = 250 mV pp from 100 Hz to 20 MHz.
- +12v = 450 mV pp from 100 Hz to 100 KHz.
= 250 mV pp from 100 KHz to 20 MHz
= 150 mV pp from 20 MHz to 80 MHz

Note. Equivalent resistance is calculated by dividing the nominal voltage by the typical RMS read/write current.

2.8.3 Voltage tolerance

Voltage tolerance (including noise):

- 5V \pm 5%
- 12V \pm 5%

2.8.4 Power-management modes

The drive provides programmable power management to provide greater energy efficiency. In most systems, you can control power management through the system setup program. The drive features the following power-management modes:

| Power modes | Heads | Spindle | Buffer |
|-------------|-----------|-----------------------|----------|
| Active | Tracking | Rotating | Enabled |
| Idle_a | ID Biased | Rotating | Enabled |
| Idle_b | Parked | Rotating | Enabled |
| Idle_c | Parked | Rotating at lower RPM | Enabled |
| Standby | Parked | Stopped | Enabled |
| Sleep | Parked | Stopped | Disabled |

- **Active mode**

The drive is in Active mode during the read/write and seek operations.

- **Idle mode**

The buffer remains enabled, and the drive accepts all commands and returns to Active mode any time disc access is necessary.

- **Standby mode**

The drive enters Standby mode when the host sends a Standby Immediate command. If the host has set the standby timer, the drive can also enter Standby mode automatically after the drive has been inactive for a specifiable length of time. The standby timer delay is established using a Standby or Idle command. In Standby mode, the drive buffer is enabled, the heads are parked and the spindle is at rest. The drive accepts all commands and returns to Active mode any time disc access is necessary.

- **Sleep mode**

The drive enters Sleep mode after receiving a Sleep command from the host. In Sleep mode, the drive buffer is disabled, the heads are parked and the spindle is at rest. The drive leaves Sleep mode after it receives a Hard Reset or Soft Reset from the host. After receiving a reset, the drive exits Sleep mode and enters Standby mode with all current translation parameters intact.

- **Idle and Standby timers**

Each time the drive performs an Active function (read, write or seek), the standby timer is reinitialized and begins counting down from its specified delay times to zero. If the standby timer reaches zero before any drive activity is required, the drive makes a transition to Standby mode. In both Idle and Standby mode, the drive accepts all commands and returns to Active mode when disc access is necessary.

2.8.4.1 Extended Power Conditions - PowerChoice™

Utilizing the load/unload architecture a programmable power management interface is provided to tailor systems for reduced power consumption and performance requirements.

The table below lists the supported power conditions available in PowerChoice. Power conditions are ordered from highest power consumption (and shortest recovery time) to lowest power consumption (and longest recovery time) as follows: Idle_a power >= Idle_b power >= Idle_c power >= Standby_z power. The further you go down in the table, the more power savings is actualized. For example, Idle_b results in greater power savings than the Idle_a power condition. Standby results in the greatest power savings.

| Power Condition Name | Power Condition ID | Description |
|----------------------|--------------------|----------------------------------------------------|
| Idle_a | 81 _H | Reduced electronics |
| Idle_b | 82 _H | Heads unloaded. Disks spinning at full RPM |
| Idle_c | 83 _H | Heads unloaded. Disks spinning at reduced RPM |
| Standby_z | 00 _H | Heads unloaded. Motor stopped (disks not spinning) |

Each power condition has a set of current, saved and default settings. Default settings are not modifiable. Default and saved settings persist across power-on resets. The current settings do not persist across power-on resets. At the time of manufacture, the default, saved and current settings are in the Power Conditions log match.

PowerChoice is invoked using one of two methods

- Automatic power transitions which are triggered by expiration of individual power condition timers. These timer values may be customized and enabled using the Extended Power Conditions (EPC) feature set using the standardized Set Features command interface.
- Immediate host commanded power transitions may be initiated using an EPC Set Features "Go to Power Condition" subcommand to enter any supported power condition. Legacy power commands Standby Immediate and Idle Immediate also provide a method to directly transition the drive into supported power conditions.

PowerChoice exits power saving states under the following conditions

- Any command which requires the drive to enter the PM0: Active state (media access)
- Power on reset

PowerChoice provides the following reporting methods for tracking purposes

Check Power Mode Command

- Reports the current power state of the drive

Identify Device Command

- EPC Feature set supported flag
- EPC Feature enabled flag is set if at least one Idle power condition timer is enabled

Power Condition Log reports the following for each power condition

- Nominal recovery time from the power condition to active
- If the power condition is Supported, Changeable, and Savable
- Default enabled state, and timer value
- Saved enabled state, and timer value
- Current enabled state, and timer value

S.M.A.R.T. Read Data Reports

- Attribute 192 - Emergency Retract Count
- Attribute 193 - Load/Unload Cycle Count

2.9 Environmental limits

Temperature and humidity values experienced by the drive must be such that condensation does not occur on any drive part. Altitude and atmospheric pressure specifications are referenced to a standard day at 58.7°F (14.8°C). Maximum wet bulb temperature is 82°F (28°C).

2.9.1 Temperature

a. Operating

The drive meets the operating specifications over a 41°F to 140°F (5°C to 60°C) drive case temperature range with a maximum temperature gradient of 36°F (20°C) per hour.

The maximum allowable drive case temperature is 60°C.

The MTBF specification for the drive assumes the operating environment is designed to maintain nominal case temperature. The rated MTBF is based upon a sustained case temperature of 104°F (40°C). Occasional excursions in operating temperature between the rated MTBF temperature and the maximum drive operating case temperature may occur without impact to the rated MTBF temperature. However continual or sustained operation at case temperatures beyond the rated MTBF temperature will degrade the drive MTBF and reduce product reliability.

Air flow may be required to achieve consistent nominal case temperature values (see Section 3.5). To confirm that the required cooling is provided for the electronics and HDA, place the drive in its final mechanical configuration, and perform random write/read operations. After the temperatures stabilize, measure the case temperature of the drive.

b. Non-operating

–40° to 158°F (–40° to 70°C) package ambient with a maximum gradient of 36°F (20°C) per hour. This specification assumes that the drive is packaged in the shipping container designed by Seagate for use with drive.

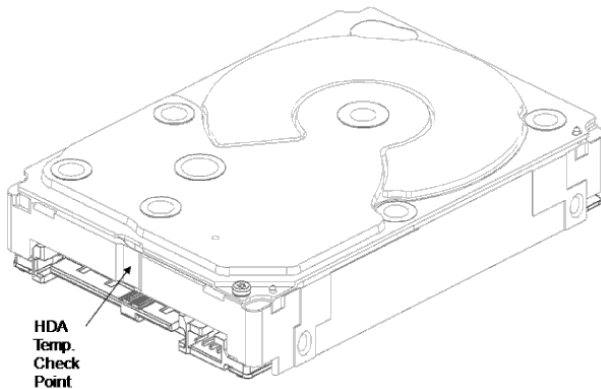

Figure 4. Location of the HDA temperature check point

2.9.2 Relative humidity

The values below assume that no condensation on the drive occurs.

a. Operating

5% to 95% non-condensing relative humidity with a maximum gradient of 20% per hour.

b. Non-operating

5% to 95% non-condensing relative humidity.

2.9.3 Effective altitude (sea level)

a. Operating

-200 to +10,000 feet (-61 to +3,048 meters)

b. Non-operating

-200 to +40,000 feet (-61 to +12,210 meters)

2.9.4 Shock

All shock specifications assume that the drive is mounted securely with the input shock applied at the drive mounting screws. Shock may be applied in the X, Y or Z axis.

2.9.4.1 Operating shock

These drives comply with the performance levels specified in this document when subjected to a maximum operating shock of Read 70 Gs and Write 40 Gs based on half-sine shock pulses of 2ms. Shocks should not be repeated more than once every 2 seconds.

2.9.4.2 Nonoperating shock

The nonoperating shock level that the drive can experience without incurring physical damage or degradation in performance when subsequently put into operation is 400 Gs based on a nonrepetitive half-sine shock pulse of 2ms duration.

2.9.5 Vibration

All vibration specifications assume that the drive is mounted securely with the input vibration applied at the drive mounting screws. Vibration may be applied in the X, Y or Z axis.

2.9.5.1 Operating vibration

The maximum vibration levels that the drive may experience while meeting the performance standards specified in this document are specified below.

| | |
|----------|---------|
| 5–500 Hz | 0.50 Gs |
|----------|---------|

2.9.5.2 Nonoperating vibration

The maximum nonoperating vibration levels that the drive may experience without incurring physical damage or degradation in performance when subsequently put into operation are specified below.

| | |
|----------|--------|
| 5–500 Hz | 3.0 Gs |
|----------|--------|

2.10 Acoustics

Drive acoustics are measured as overall A-weighted acoustic sound power levels (no pure tones). All measurements are consistent with ISO document 7779. Sound power measurements are taken under essentially free-field conditions over a reflecting plane. For all tests, the drive is oriented with the cover facing upward.

Note. For seek mode tests, the drive is placed in seek mode only. The number of seeks per second is defined by the following equation:

$$(\text{Number of seeks per second} = 0.4 / (\text{average latency} + \text{average access time}))$$

Table 3: Fluid Dynamic Bearing (FDB) motor acoustics

| Active | Idle* |
|----------------|----------------|
| 2.8 bels (typ) | 2.2 bels (typ) |

*During periods of drive idle, some offline activity may occur according to the S.M.A.R.T. specification, which may increase acoustic and power to operational levels.

2.11 Electromagnetic immunity

When properly installed in a representative host system, the drive operates without errors or degradation in performance when subjected to the radio frequency (RF) environments defined in the following table:

Table 4: Radio frequency environments

| Test | Description | Performance level | Reference standard |
|---------------------------|-------------------------------------------------------------------------------------------------|-------------------|-----------------------------------|
| Electrostatic discharge | Contact, HCP, VCP: ± 4 kV; Air: ± 8 kV | B | EN 61000-4-2: 95 |
| Radiated RF immunity | 80 to 1,000 MHz, 3 V/m, 80% AM with 1 kHz sine 900 MHz, 3 V/m, 50% pulse modulation @ 200 Hz | A | EN 61000-4-3: 96 ENV 50204: 95 |
| Electrical fast transient | ± 1 kV on AC mains, ± 0.5 kV on external I/O | B | EN 61000-4-4: 95 |
| Surge immunity | ± 1 kV differential, ± 2 kV common, AC mains | B | EN 61000-4-5: 95 |
| Conducted RF immunity | 150 kHz to 80 MHz, 3 Vrms, 80% AM with 1 kHz sine | A | EN 61000-4-6: 97 |
| Voltage dips, interrupts | 0% open, 5 seconds 0% short, 5 seconds 40%, 0.10 seconds 70%, 0.01 seconds | C C C B | EN 61000-4-11: 94 |

2.12 Reliability

2.12.1 Annualized Failure Rate (AFR) and Mean Time Between Failures (MTBF)

The product shall achieve an Annualized Failure Rate - AFR - of 0.62% (Mean Time Between Failures - MTBF - of 1.4 Million hrs) when operated in an environment that ensures the HDA case temperatures do not exceed 40°C. Operation at case temperatures outside the specifications in Section 2.9 may increase the product Annualized Failure Rate (decrease MTBF). AFR and MTBF are population statistics that are not relevant to individual units.

AFR and MTBF specifications are based on the following assumptions for business critical storage system environments:

- 8760 power-on-hours per year.
- 250 average motor start/stop cycles per year.
- Operations at nominal voltages.
- Systems will provide adequate cooling to ensure the case temperatures do not exceed 40°C. Temperatures outside the specifications in Section 2.8 will increase the product AFR and decrease MTBF.

| | |
|-------------------------------|-------------------------------------------------------------------------------------------------------------------------------------------------------------------------------------------------------------------------------------------------------------------------------------------------------------------------------------------------------------------------------------------------------------------------------------------------------------------------------------------------------------------------------|
| Nonrecoverable read errors | 1 per 10 ¹⁵ bits read, max |
| Annualized Failure Rate (AFR) | 0.62% (nominal power, 40°C case temperature) |
| Load/unload cycles | 300,000 cycles |
| Warranty | To determine the warranty for a specific drive, use a web browser to access the following web page: http://www.seagate.com/services-software/seagate-recovery-services/recover/ From this page, click on the "Is my Drive under Warranty" link. You will be asked to provide the drive serial number, model number (or part number) and country of purchase. The system will display the warranty information for your drive. |
| Preventive maintenance | None required. |

2.13 Agency certification

2.13.1 Safety certification

The drives are recognized in accordance with UL 60950-1 as tested by UL, CSA 60950-1 as tested by CSA, and EN60950-1 as tested by TUV.

The security features of Self-Encrypting Drive models are based on the "TCG Storage Architecture Core Specification" and the "TCG Storage Workgroup Security Subsystem Class: Enterprise_A" specification with additional vendor-unique features as noted in this product manual.

2.13.2 Electromagnetic compatibility

Hard drives that display the CE mark comply with the European Union (EU) requirements specified in the Electromagnetic Compatibility Directive (2004/108/EC) as put into place 20 July 2007. Testing is performed to the levels specified by the product standards for Information Technology Equipment (ITE). Emission levels are defined by EN 55022, Class B and the immunity levels are defined by EN 55024.

Seagate uses an independent laboratory to confirm compliance with the EC directives specified in the previous paragraph. Drives are tested in representative end-user systems. Although CE-marked Seagate drives comply with the directives when used in the test systems, we cannot guarantee that all systems will comply with the directives. The drive is designed for operation inside a properly designed enclosure, with properly shielded I/O cable (if necessary) and terminators on all unused I/O ports. Computer manufacturers and system integrators should confirm EMC compliance and provide CE marking for their products.

Korean RRL

If these drives have the Korean Communications Commission (KCC) logo, they comply with paragraph 1 of Article 11 of the Electromagnetic Compatibility control Regulation and meet the Electromagnetic Compatibility (EMC) Framework requirements of the Radio Research Laboratory (RRL) Communications Commission, Republic of Korea.

These drives have been tested and comply with the Electromagnetic Interference/Electromagnetic Susceptibility (EMI/EMS) for Class B products. Drives are tested in a representative, end-user system by a Korean-recognized lab.

- Family name: Constellation.2 Serial ATA
- Certificate number: STX- ST91000640NS (B)

Australian C-Tick (N176)

If these models have the C-Tick marking, they comply with the Australia/New Zealand Standard AS/NZ CISPR22 and meet the Electromagnetic Compatibility (EMC) Framework requirements of the Australian Communication Authority (ACA).

2.13.3 FCC verification

These drives are intended to be contained solely within a personal computer or similar enclosure (not attached as an external device). As such, each drive is considered to be a subassembly even when it is individually marketed to the customer. As a subassembly, no Federal Communications Commission verification or certification of the device is required.

Seagate Technology LLC has tested this device in enclosures as described above to ensure that the total assembly (enclosure, disc drive, motherboard, power supply, etc.) does comply with the limits for a Class B computing device, pursuant to Subpart J, Part 15 of the FCC rules. Operation with noncertified assemblies is likely to result in interference to radio and television reception.

Radio and television interference. This equipment generates and uses radio frequency energy and if not installed and used in strict accordance with the manufacturer's instructions, may cause interference to radio and television reception.

This equipment is designed to provide reasonable protection against such interference in a residential installation. However, there is no guarantee that interference will not occur in a particular installation. If this equipment does cause interference to radio or television, which can be determined by turning the equipment on and off, you are encouraged to try one or more of the following corrective measures:

- Reorient the receiving antenna.
- Move the device to one side or the other of the radio or TV.
- Move the device farther away from the radio or TV.
- Plug the computer into a different outlet so that the receiver and computer are on different branch outlets.

If necessary, you should consult your dealer or an experienced radio/television technician for additional suggestions. You may find helpful the following booklet prepared by the Federal Communications Commission: *How to Identify and Resolve Radio-Television Interference Problems*. This booklet is available from the Superintendent of Documents, U.S. Government Printing Office, Washington, DC 20402. Refer to publication number 004-000-00345-4.

2.14 Environmental protection

Seagate designs its products to meet environmental protection requirements worldwide, including regulations restricting certain chemical substances.

2.14.1 European Union Restriction of Hazardous Substances (RoHS) Directive

The European Union Restriction of Hazardous Substances (RoHS) Directive, restricts the presence of chemical substances, including Lead, Cadmium, Mercury, Hexavalent Chromium, PBB and PBDE, in electronic products, effective July 2006. This drive is manufactured with components and materials that comply with the RoHS Directive.

2.14.2 China Restriction of Hazardous Substances (RoHS) Directive 中国限制危险物品的指令

This product has an Environmental Protection Use Period (EPUP) of 20 years. The following table contains information mandated by China's "Marking Requirements for Control of Pollution Caused by Electronic Information Products" Standard.



该产品具有20年的环境保护使用周期（EPUP）。下表包含了中国“电子产品所导致的污染的控制的记号要求”所指定的信息。

| Name of Parts 部件名称 | Toxic or Hazardous Substances or Elements有毒有害物质或元素 | | | | | |
|-----------------------|----------------------------------------------------|----------------------|----------------------|-----------------------------------------|---------------------------------------------|-----------------------------------------------------|
| | Lead 铅 (Pb) | Mercury 汞 (Hg) | Cadmium 镉 (Cd) | Hexavalent Chromium 六价铬 (Cr6+) | Polybrominated Diphenyl 多溴联苯 (PBB) | Polybrominated Diphenyl Ether 多溴二苯醚 (PBDE) |
| PCBA | X | O | O | O | O | O |
| HDA | X | O | O | O | O | O |

"O" indicates the hazardous and toxic substance content of the part (at the homogeneous material level) is lower than the threshold defined by the China RoHS MCV Standard.

“O”表示该部件（于同类物品程度上）所含的危险和有毒物质低于中国RoHS MCV标准所定义的门槛值。

"X" indicates the hazardous and toxic substance content of the part (at the homogeneous material level) is over the threshold defined by the China RoHS MCV Standard.

“X”表示该部件（于同类物品程度上）所含的危险和有毒物质超出中国RoHS MCV标准所定义的门槛值。

2.15 Corrosive environment

Seagate electronic drive components pass accelerated corrosion testing equivalent to 10 years exposure to light industrial environments containing sulfurous gases, chlorine and nitric oxide, classes G and H per ASTM B845. However, this accelerated testing cannot duplicate every potential application environment. Users should use caution exposing any electronic components to uncontrolled chemical pollutants and corrosive chemicals as electronic drive component reliability can be affected by the installation environment. The silver, copper, nickel and gold films used in Seagate products are especially sensitive to the presence of sulfide, chloride, and nitrate contaminants. Sulfur is found to be the most damaging. In addition, electronic components should never be exposed to condensing water on the surface of the printed circuit board assembly (PCBA) or exposed to an ambient relative humidity greater than 95%. Materials used in cabinet fabrication, such as vulcanized rubber, that can outgas corrosive compounds should be minimized or eliminated. The useful life of any electronic equipment may be extended by replacing materials near circuitry with sulfide-free alternatives.

2.16 Reference documents

Self-Encrypting Drives Reference Manual

Seagate part number: 100515636

Trusted Computing Group (TCG) Documents (apply to Self-Encrypting Drive models only)

TCG Storage Architecture Core Specification, Rev. 1.0

TCG Storage Security Subsystem Class Enterprise Specification, Rev. 1.0

In case of conflict between this document and any referenced document, this document takes precedence.

2.17 Product warranty

Beginning on the date of shipment to the customer and continuing for the period specified in your purchase contract, Seagate warrants that each product (including components and subassemblies) that fails to function properly under normal use due to defect in materials or workmanship or due to nonconformance to the applicable specifications will be repaired or replaced, at Seagate's option and at no charge to the customer, if returned by customer at customer's expense to Seagate's designated facility in accordance with Seagate's warranty procedure. Seagate will pay for transporting the repair or replacement item to the customer. For more detailed warranty information, refer to the standard terms and conditions of purchase for Seagate products on your purchase documentation.

The remaining warranty for a particular drive can be determined by calling Seagate Customer Service at 1-800-468-3472. You can also determine remaining warranty using the Seagate web site (www.seagate.com). The drive serial number is required to determine remaining warranty information.

Shipping

When transporting or shipping a drive, use only a Seagate-approved container. Keep your original box. Seagate approved containers are easily identified by the Seagate Approved Package label. Shipping a drive in a non-approved container voids the drive warranty.

Seagate repair centers may refuse receipt of components improperly packaged or obviously damaged in transit. Contact your authorized Seagate distributor to purchase additional boxes. Seagate recommends shipping by an air-ride carrier experienced in handling computer equipment.

Storage

Maximum storage periods are 180 days within original unopened Seagate shipping package or 60 days unpackaged within the defined non-operating limits (refer to environmental section in this manual). Storage can be extended to 1 year packaged or unpackaged under optimal environmental conditions (25°C, <40% relative humidity non-condensing, and non-corrosive environment). During any storage period the drive non-operational temperature, humidity, wet bulb, atmospheric conditions, shock, vibration, magnetic and electrical field specifications should be followed.

Product repair and return information

Seagate customer service centers are the only facilities authorized to service Seagate drives. Seagate does not sanction any third-party repair facilities. Any unauthorized repair or tampering with the factory seal voids the warranty.

3.0 Configuring and mounting the drive

This section contains the specifications and instructions for configuring and mounting the drive.

3.1 Handling and static-discharge precautions

After unpacking, and before installation, the drive may be exposed to potential handling and electrostatic discharge (ESD) hazards. Observe the following standard handling and static-discharge precautions:

Caution:

- Before handling the drive, put on a grounded wrist strap, or ground yourself frequently by touching the metal chassis of a computer that is plugged into a grounded outlet. Wear a grounded wrist strap throughout the entire installation procedure.
- Handle the drive by its edges or frame *only*.
- The drive is extremely fragile—handle it with care. Do not press down on the drive top cover.
- Always rest the drive on a padded, antistatic surface until you mount it in the computer.
- Do not touch the connector pins or the printed circuit board.
- Do not remove the factory-installed labels from the drive or cover them with additional labels. Removal voids the warranty. Some factory-installed labels contain information needed to service the drive. Other labels are used to seal out dirt and contamination.

3.2 Configuring the drive

Each drive on the Serial ATA interface connects point-to-point with the Serial ATA host adapter. There is no master/slave relationship because each drive is considered a master in a point-to-point relationship. If two drives are attached on one Serial ATA host adapter, the host operating system views the two devices as if they were both “masters” on two separate ports. Both drives behave as if they are Device 0 (master) devices.

Serial ATA drives are designed for easy installation. It is usually not necessary to set any jumpers on the drive for proper operation; however, if you connect the drive and receive a “drive not detected” error, your SATA-equipped motherboard or host adapter may use a chipset that does not support SATA speed autonegotiation.

3.3 Serial ATA cables and connectors

The Serial ATA interface cable consists of four conductors in two differential pairs, plus three ground connections. The cable size may be 30 to 26 AWG with a maximum length of one meter (39.37in). See Table 5 for connector pin definitions. Either end of the SATA signal cable can be attached to the drive or host.

For direct backplane connection, the drive connectors are inserted directly into the host receptacle. The drive and the host receptacle incorporate features that enable the direct connection to be hot pluggable and blind mateable.

For installations which require cables, you can connect the drive as illustrated in Figure 5, page 29.

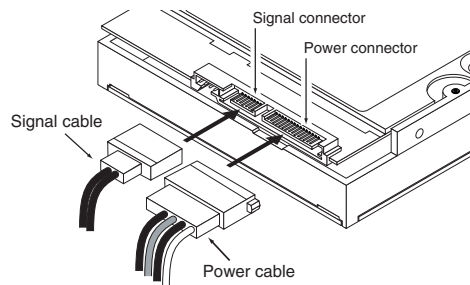

Figure 5. Attaching SATA cabling

Each cable is keyed to ensure correct orientation. Constellation.2 Serial ATA drives support latching SATA connectors.

3.4 Drive mounting

You can mount the drive in any orientation using four screws in the side-mounting holes or four screws in the bottom-mounting holes. See Figure 6, page 30 for drive mounting dimensions. Follow these important mounting precautions when mounting the drive:

- Allow a minimum clearance of 0.030 in (0.76 mm) around the entire perimeter of the drive for cooling as a guideline. Please refer to Section 3.5 for final cooling requirements.
- Use only M3 x 0.5 metric mounting screws.
- Four (4) threads (0.080 in) minimum screw engagement recommended. Also ensure maximum screw length does not bottom out in mounting holes.
- Do not overtighten the mounting screws (maximum torque: 4.5 in-lb, \pm 0.45 in-lb)

3.4.1 Mechanical specifications

Refer to Figure 6, page 30 for detailed mounting configuration dimensions. See Section 3.4, "Drive mounting.

| | | |
|-------------------|--------------|------------------|
| Weight: (maximum) | 1TB models | 200 g (0.441 lb) |
| | 500GB models | 183 g (0.403 lb) |
| | 250GB models | 179 g (0.395 lb) |

Note. These dimensions conform to the Small Form Factor Standard documented in SFF-8201 and SFF-8223 found at www.sffcommittee.org.

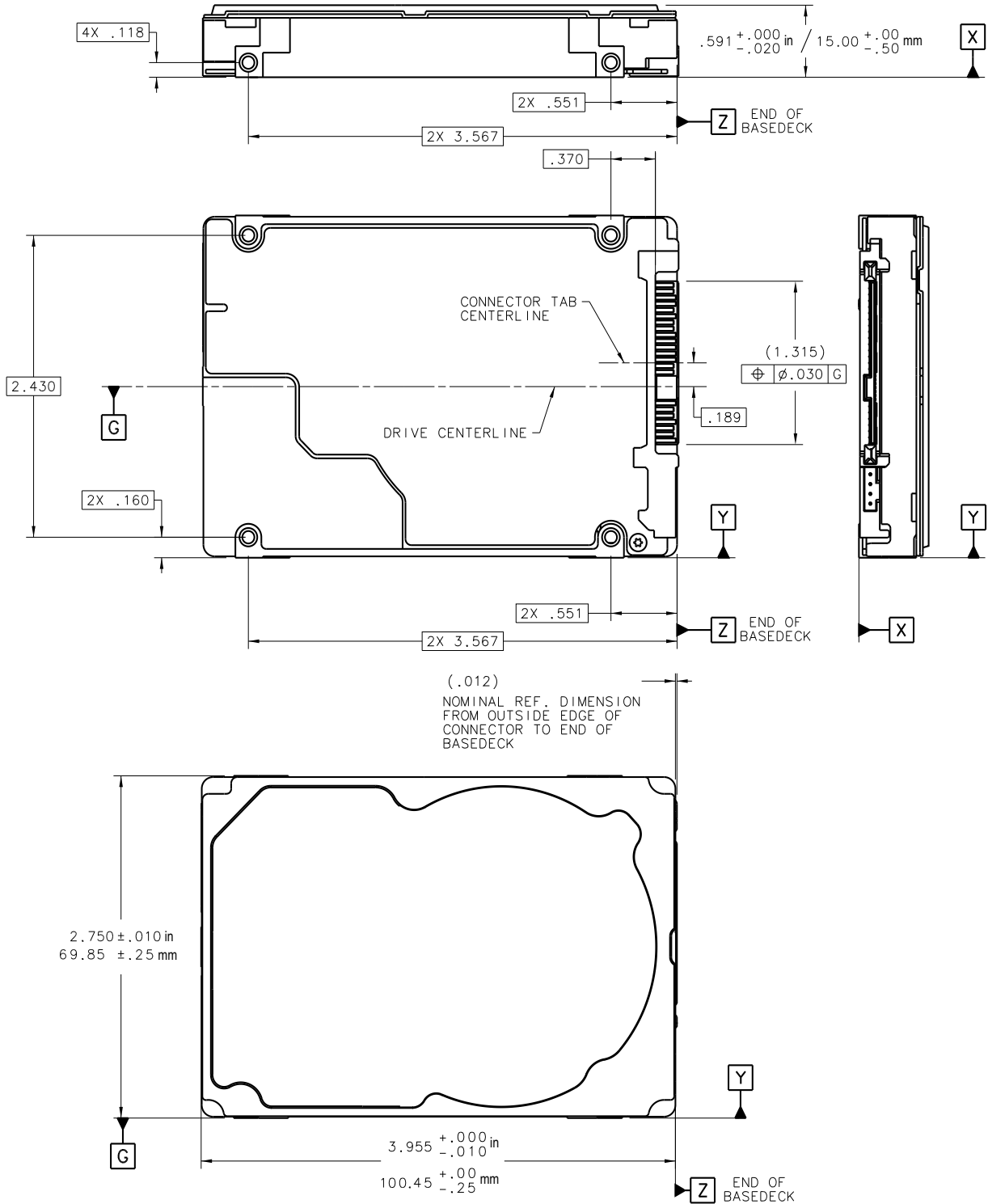

Figure 6. Mounting dimensions—top, side and end view

3.5 Cooling

Cabinet cooling must be designed by the customer so that the ambient temperature immediately surrounding the drive will not exceed temperature conditions specified in Section 2.9.1, "Temperature."

The rack, cabinet, or drawer environment for the drive must provide heat removal from the electronics and head and disc assembly (HDA). You should confirm that adequate heat removal is provided using the temperature measurement guidelines described in Section 2.9.1.

Forced air flow may be required to keep temperatures at or below the temperatures specified in Section 2.9.1 in which case the drive should be oriented, or air flow directed, so that the least amount of air flow resistance is created while providing air flow to the electronics and HDA. Also, the shortest possible path between the air inlet and exit should be chosen to minimize the travel length of air heated by the drive and other heat sources within the rack, cabinet, or drawer environment.

If forced air is determined to be necessary, possible air-flow patterns are shown in Figure 7, page 31. The air-flow patterns are created by one or more fans, either forcing or drawing air as shown in the illustrations. Conduction, convection, or other forced air-flow patterns are acceptable as long as the temperature measurement guidelines of Section 2.9.1 are met.

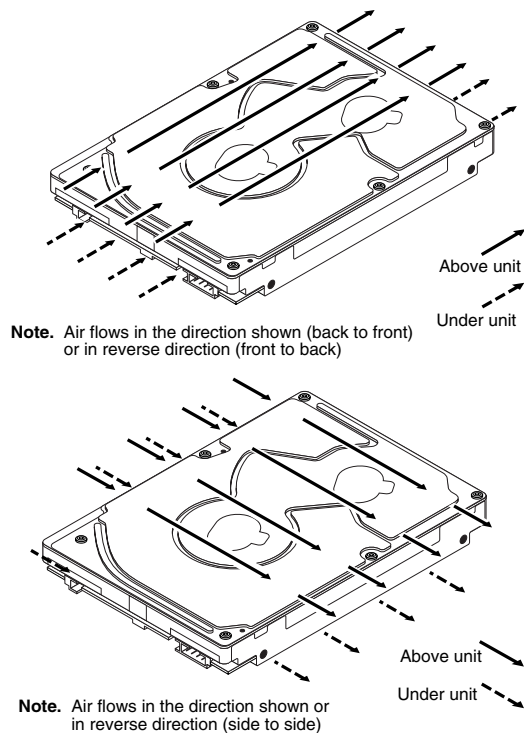

Figure 7. Air flow

4.0 About FIPS

The Federal Information Processing Standard (FIPS) Publication 140-2 is a U.S. Government Computer Security Standard used to accredit cryptographic modules. It is titled 'Security Requirements for Cryptographic Modules (FIPS PUB 140-2)' and is issued by the National Institute of Standards and Technology (NIST).

Purpose

This standard specifies the security requirements that will be satisfied by a cryptographic module utilized within a security system protecting sensitive but unclassified information. The standard provides four increasing, qualitative levels of security: Level 1, Level 2, Level 3 and Level 4. These levels are intended to cover the wide range of potential applications and environments in which cryptographic modules may be employed.

Seagate Enterprise SEDs

The SEDs referenced in this Product Manual have been validated by CMVP and have been thoroughly tested by a NVLAP accredited lab to satisfy FIPS 140-2 Level 2 requirements. In order to operate in FIPS Approved Mode of Operation, these SEDs require security initialization. For more information, refer to 'Security Rules' section in the 'Security Policy' document uploaded on the NIST website. To reference the product certification visit - <http://csrc.nist.gov/groups/STM/cmvp/documents/140-1/1401vend.htm> and search for "Seagate".

Level 2 security

Security Level 2 enhances the physical security mechanisms of a Security Level 1 cryptographic module by adding the requirement for tamper-evidence, which includes the use of tamper-evident coatings or seals on removable covers of the module. Tamper-evident coatings or seals are placed on a cryptographic module so that the coating or seal must be broken to attain physical access to the critical security parameters (CSP) within the module. Tamper-evident seals are placed on covers to protect against unauthorized physical access. In addition Security Level 2 requires, at a minimum, role-based authentication in which a cryptographic module authenticates the authorization of an operator to assume a specific role and perform a corresponding set of services.

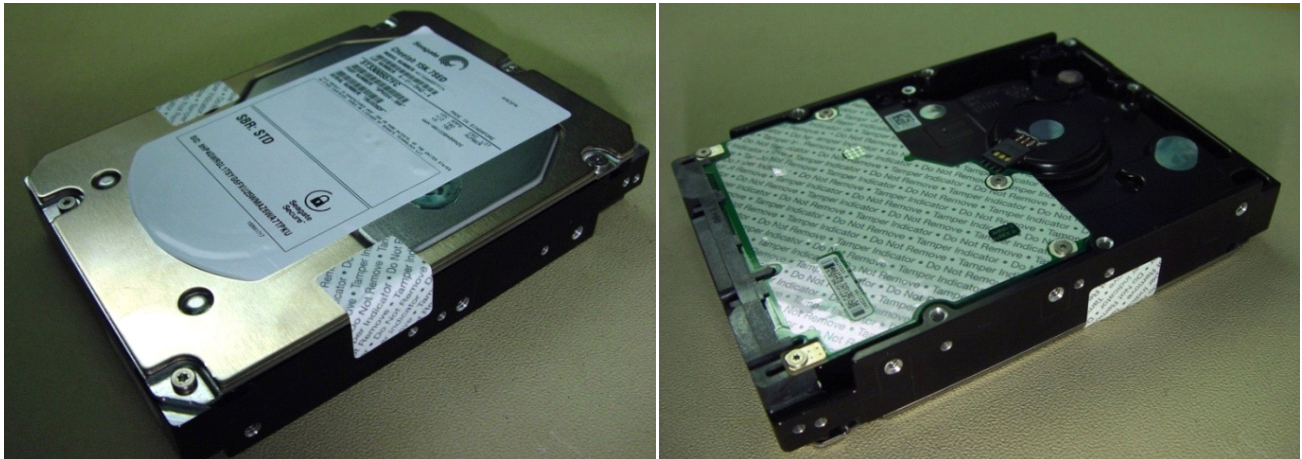

Figure 8. Example of FIPS tamper evidence labels.

Note. Does not represent actual drive.

5.0 About self-encrypting drives

Self-encrypting drives (SEDs) offer encryption and security services for the protection of stored data, commonly known as “protection of data at rest.” These drives are compliant with the Trusted Computing Group (TCG) Enterprise Storage Specifications as detailed in Section 2.16.

The Trusted Computing Group (TCG) is an organization sponsored and operated by companies in the computer, storage and digital communications industry. Seagate’s SED models comply with the standards published by the TCG.

To use the security features in the drive, the host must be capable of constructing and issuing the following two ATA commands:

- Trusted Send
- Trusted Receive

These commands are used to convey the TCG protocol to and from the drive in their command payloads.

5.1 Data encryption

Encrypting drives use one inline encryption engine for each port, employing AES-256 data encryption in Cipher Block Chaining (CBC) mode to encrypt all data prior to being written on the media and to decrypt all data as it is read from the media. The encryption engines are always in operation and cannot be disabled.

The 32-byte Data Encryption Key (DEK) is a random number which is generated by the drive, never leaves the drive, and is inaccessible to the host system. The DEK is itself encrypted when it is stored on the media and when it is in volatile temporary storage (DRAM) external to the encryption engine. A unique data encryption key is used for each of the drive's possible 16 data bands (see Section 5.5).

5.2 Controlled access

The drive has two security providers (SPs) called the "Admin SP" and the "Locking SP." These act as gatekeepers to the drive security services. Security-related commands will not be accepted unless they also supply the correct credentials to prove the requester is authorized to perform the command.

5.2.1 Admin SP

The Admin SP allows the drive's owner to enable or disable firmware download operations (see Section 5.4). Access to the Admin SP is available using the SID (Secure ID) password or the MSID (Manufacturers Secure ID) password.

5.2.2 Locking SP

The Locking SP controls read/write access to the media and the cryptographic erase feature. Access to the Locking SP is available using the BandMasterX or EraseMaster passwords. Since the drive owner can define up to 16 data bands on the drive, each data band has its own password called BandMasterX where X is the number of the data band (0 through 15).

5.2.3 Default password

When the drive is shipped from the factory, all passwords are set to the value of MSID. This 32-byte random value can only be read by the host electronically over the interface. After receipt of the drive, it is the responsibility of the owner to use the default MSID password as the authority to change all other passwords to unique owner-specified values.

5.3 Random number generator (RNG)

The drive has a 32-byte hardware RNG that it uses to derive encryption keys or, if requested to do so, to provide random numbers to the host for system use, including using these numbers as Authentication Keys (passwords) for the drive's Admin and Locking SPs.

5.4 Drive locking

In addition to changing the passwords, as described in Section 5.2.3, the owner should also set the data access controls for the individual bands. The variable "LockOnReset" should be set to "PowerCycle" to ensure that the data bands will be locked if power is lost. In addition "ReadLockEnabled" and "WriteLockEnabled" must be set to true in the locking table in order for the bands "LockOnReset" setting of "PowerCycle" to actually lock access to the band when a "PowerCycle" event occurs. This scenario occurs if the drive is removed from its cabinet. The drive will not honor any data read or write requests until the bands have been unlocked. This prevents the user data from being accessed without the appropriate credentials when the drive has been removed from its cabinet and installed in another system.

When the drive is shipped from the factory, the firmware download port is unlocked.

5.5 Data bands

When shipped from the factory, the drive is configured with a single data band called Band 0 (also known as the Global Data Band) which comprises LBA 0 through LBA max. The host may allocate Band1 by specifying a start LBA and an LBA range. The real estate for this band is taken from the Global Band. An additional 14 Data Bands may be defined in a similar way (Band2 through Band15) but before these bands can be allocated LBA space, they must first be individually enabled using the EraseMaster password.

Data bands cannot overlap but they can be sequential with one band ending at LBA (x) and the next beginning at LBA (x+1).

Each data band has its own drive-generated encryption key and its own user-supplied password. The host may change the Encryption Key (see Section 5.6) or the password when required. The bands should be aligned to 4K LBA boundaries.

5.6 Cryptographic erase

A significant feature of SEDs is the ability to perform a cryptographic erase. This involves the host telling the drive to change the data encryption key for a particular band. Once changed, the data is no longer recoverable since it was written with one key and will be read using a different key. Since the drive overwrites the old key with the new one, and keeps no history of key changes, the user data can never be recovered. This is tantamount to an instantaneous data erase and is very useful if the drive is to be scrapped or repositioned.

5.7 Authenticated firmware download

In addition to providing a locking mechanism to prevent unwanted firmware download attempts, the drive also only accepts download files which have been cryptographically signed by the appropriate Seagate Design Center.

Three conditions must be met before the drive will allow the download operation:

1. The download must be an SED file. A standard (base) drive (non-SED) file will be rejected.
2. The download file must be signed and authenticated.

3. As with a non-SED drive, the download file must pass the acceptance criteria for the drive. For example it must be applicable to the correct drive model, and have compatible revision and customer status.

5.8 Power requirements

The standard drive models and the SED drive models have identical hardware, however the security and encryption portion of the drive controller ASIC is enabled and functional in the SED models. This represents a small additional drain on the 5V supply of about 30mA and a commensurate increase of about 150mW in power consumption. There is no additional drain on the 12V supply. See the tables in Section 2.8 for power requirements on the standard (non-SED) drive models.

5.9 Supported commands

The SED models support the following two commands in addition to the commands supported by the standard (non-SED) models as listed in Table 6:

- Trusted Send (5Eh) or Trusted Send DMA (5Fh)
- Trusted Receive (5Ch) or Trusted Receive DMA (5Dh)

5.10 RevertSP

SED models will support the RevertSP feature which erases all data in all bands on the device and returns the contents of all SPs (Security Providers) on the device to their original factory state. In order to execute the RevertSP method the unique PSID (Physical Secure ID) printed on the drive label must be provided. PSID is not electronically accessible and can only be manually read from the drive label or scanned in via the 2D barcode.

5.11 ATA Security Erase Unit Command on SED drives

The ATA SECURITY ERASE UNIT command shall support both the Normal and Enhanced erase modes with the following modifications/additions:

- Normal Erase: Normal erase shall be accomplished by changing the media encryption key for the drive followed by an overwrite operation that repeatedly writes a single sector containing random data to the entire drive. The write operation shall bypass the media encryption. On reading back the overwritten sectors, the host will receive a decrypted version, using the new encryption key, of the random data sector (the returned data will not match what was written).
- Enhanced Erase: Enhanced erase shall be accomplished by changing the media encryption key for the drive.

5.12 Sanitize Device - CRYPTO SCRAMBLE EXT

This command cryptographically erases all user data on the drive by destroying the current data encryption key and replacing it with a new data encryption key randomly generated by the drive. Sanitize Device is a command field B4h and Feature field 0011h (CRYPTO SCRAMBLE EXT).

The drive shall support the Sanitize Feature Set as defined in ANSI/INCITS ACS-2 with the exceptions and/or modifications described in this section.

The drive shall not support the OVERWRITE EXT and BLOCK ERASE EXT sub-commands.

Support of the SANITIZE FREEZE LOCK EXT command shall be determined on a customer-specific basis. OEM drives shall support the command.

6.0 Serial ATA (SATA) interface

These drives use the industry-standard Serial ATA interface that supports FIS data transfers. It supports ATA programmed input/output (PIO) modes 0–4; multiword DMA modes 0–2, and Ultra DMA modes 0–6.

For detailed information about the Serial ATA interface, refer to the “Serial ATA: High Speed Serialized AT Attachment” specification.

6.1 Hot-Plug compatibility

Constellation.2 Serial ATA drives incorporate connectors which enable you to hot plug these drives in accordance with the Serial ATA II: Extension to Serial ATA 1.0a specification. This specification can be downloaded from: www.serialata.org.

Caution:

The drive motor must come to a complete stop (**Ready to spindle stop time indicated in Section 2.7**) prior to changing the plane of operation. This time is required to insure data integrity.

6.2 Serial ATA device plug connector pin definitions

Table 5 summarizes the signals on the Serial ATA interface and power connectors.

Table 5: Serial ATA connector pin definitions

| Segment | Pin | Function | Definition |
|---------------|-----|----------|-------------------------------------|
| Signal | S1 | Ground | 2nd mate |
| | S2 | A+ | Differential signal pair A from Phy |
| | S3 | A- | |
| | S4 | Ground | 2nd mate |
| | S5 | B- | Differential signal pair B from Phy |
| | S6 | B+ | |
| | S7 | Ground | 2nd mate |

Key and spacing separate signal and power segments

| | | | |
|--------------|-----|----------------------|-----------------------------------------------|
| Power | P1 | V ₃₃ | 3.3V power |
| | P2 | V ₃₃ | 3.3V power |
| | P3 | V ₃₃ | 3.3V power, pre-charge, 2nd mate |
| | P4 | Ground | 1st mate |
| | P5 | Ground | 2nd mate |
| | P6 | Ground | 2nd mate |
| | P7 | V ₅ | 5V power, pre-charge, 2nd mate |
| | P8 | V ₅ | 5V power |
| | P9 | V ₅ | 5V power |
| | P10 | Ground | 2nd mate |
| | P11 | Ground or LED signal | If grounded, drive does not use deferred spin |
| | P12 | Ground | 1st mate. |
| | P13 | V ₁₂ | 12V power, pre-charge, 2nd mate |
| | P14 | V ₁₂ | 12V power |
| | P15 | V ₁₂ | 12V power |

Notes:

- All pins are in a single row, with a 1.27 mm (0.050") pitch.
- The comments on the mating sequence apply to the case of backplane blindmate connector only. In this case, the mating sequences are:
 - the ground pins P4 and P12.
 - the pre-charge power pins and the other ground pins.
 - the signal pins and the rest of the power pins.
- There are three power pins for each voltage. One pin from each voltage is used for pre-charge when installed in a blind-mate backplane configuration.
- All used voltage pins (V_x) must be terminated.

6.3 Supported ATA commands

The following table lists Serial ATA standard commands that the drive supports. For a detailed description of the ATA commands, refer to the Serial ATA: High Speed Serialized AT Attachment specification. See “S.M.A.R.T. commands” on page 45 for details and subcommands used in the S.M.A.R.T. implementation.

Table 6: Supported ATA commands

| Command name | Command code (in hex) |
|---------------------------------------|-------------------------------------|
| Check Power Mode | E5 _H |
| Device Configuration Freeze Lock | B1 _H / C1 _H |
| Device Configuration Identify | B1 _H / C2 _H |
| Device Configuration Restore | B1 _H / C0 _H |
| Device Configuration Set | B1 _H / C3 _H |
| Device Reset | 08 _H |
| Download Microcode | 92 _H |
| Execute Device Diagnostics | 90 _H |
| Flush Cache | E7 _H |
| Flush Cache Extended | EA _H |
| Format Track | 50 _H |
| Identify Device | EC _H |
| Idle | E3 _H |
| Idle Immediate | E1 _H |
| Initialize Device Parameters | 91 _H |
| Read Buffer | E4 _H |
| Read DMA | C8 _H |
| Read DMA Extended | 25 _H |
| Read DMA Without Retries | C9 _H |
| Read Log Ext | 2F _H |
| Read Multiple | C4 _H |
| Read Multiple Extended | 29 _H |
| Read Native Max Address | F8 _H |
| Read Native Max Address Extended | 27 _H |
| Read Sectors | 20 _H |
| Read Sectors Extended | 24 _H |
| Read Sectors Without Retries | 21 _H |
| Read Verify Sectors | 40 _H |
| Read Verify Sectors Extended | 42 _H |
| Read Verify Sectors Without Retries | 41 _H |
| Recalibrate | 10 _H |
| Sanitize Device - Status Ext | B4 _H / 0000 _H |
| Sanitize Device - Crypto Scramble Ext | B4 _H / 0011 _H |
| Sanitize Device - Freeze Lock Ext | B4 _H / 0020 _H |

| Command name | Command code (in hex) |
|---------------------------------------------------------------------------------------------------------------------------------------------------------------|------------------------------------------------------------------------------------------------------------------------------------------------------------------|
| Security Disable Password | F6 _H |
| Security Erase Prepare | F3 _H |
| Security Erase Unit | F4 _H |
| Security Freeze | F5 _H |
| Security Set Password | F1 _H |
| Security Unlock | F2 _H |
| Seek | 70 _H |
| Set Features | EF _H |
| Set Max Address Note: Individual Set Max Address commands are identified by the value placed in the Set Max Features register as defined to the right. | F9 _H Address: 00 _H Password: 01 _H Lock: 02 _H Unlock: 03 _H Freeze Lock: 04 _H |
| Set Max Address Extended | 37 _H |
| Set Multiple Mode | C6 _H |
| Sleep | E6 _H |
| S.M.A.R.T. Disable Operations | B0 _H / D9 _H |
| S.M.A.R.T. Enable/Disable Autosave | B0 _H / D2 _H |
| S.M.A.R.T. Enable Operations | B0 _H / D8 _H |
| S.M.A.R.T. Execute Offline | B0 _H / D4 _H |
| S.M.A.R.T. Read Attribute Thresholds | B0 _H / D1 _H |
| S.M.A.R.T. Read Data | B0 _H / D0 _H |
| S.M.A.R.T. Read Log Sector | B0 _H / D5 _H |
| S.M.A.R.T. Return Status | B0 _H / DA _H |
| S.M.A.R.T. Save Attribute Values | B0 _H / D3 _H |
| S.M.A.R.T. Write Log Sector | B0 _H / D6 _H |
| Standby | E2 _H |
| Standby Immediate | E0 _H |
| Trusted Send | 5E _H (SED drives only) |
| Trusted Send DMA | 5F _H (SED drives only) |
| Trusted Receive | 5C _H (SED drives only) |
| Trusted Receive DMA | 5D _H (SED drives only) |
| Write Buffer | E8 _H |
| Write DMA | CA _H |
| Write DMA Extended | 35 _H |
| Write DMA FUA Extended | CD _H |
| Write DMA Without Retries | CB _H |
| Write Log Extended | 3F _H |
| Write Multiple | C5 _H |
| Write Multiple Extended | 39 _H |

| Command name | Command code (in hex) |
|-------------------------------|-----------------------|
| Write Multiple FUA Extended | CE _H |
| Write Sectors | 30 _H |
| Write Sectors Without Retries | 31 _H |
| Write Sectors Extended | 34 _H |

6.3.1 Identify Device command

The Identify Device command (command code EC_H) transfers information about the drive to the host following power up. The data is organized as a single 512-byte block of data, whose contents are shown in Table 6 on page 38. All reserved bits or words should be set to zero. Parameters listed with an “x” are drive-specific or vary with the state of the drive. See Section 2.0 on page 9 for default parameter settings.

The following commands contain drive-specific features that may not be included in the Serial ATA specification.

| Word | Description | Value |
|-------|----------------------------------------------------------------------------------------------------------------------------------------------|-------------------|
| 0 | Configuration information: • Bit 15: 0 = ATA; 1 = ATAPI • Bit 7: removable media • Bit 6: removable controller • Bit 0: reserved | 0C5A _H |
| 1 | Number of logical cylinders | 16,383 |
| 2 | ATA-reserved | 0000 _H |
| 3 | Number of logical heads | 16 |
| 4 | Retired | 0000 _H |
| 5 | Retired | 0000 _H |
| 6 | Number of logical sectors per logical track: 63 | 003F _H |
| 7–9 | Retired | 0000 _H |
| 10–19 | Serial number: (20 ASCII characters, 0000 _H = none) | ASCII |
| 20 | Retired | 0000 _H |
| 21 | Retired | 0400 _H |
| 22 | Obsolete | 0000 _H |
| 23–26 | Firmware revision (8 ASCII character string, padded with blanks to end of string) | x.xx |
| 27–46 | Drive model number: (40 ASCII characters, padded with blanks to end of string) | |
| 47 | (Bits 7–0) Maximum sectors per interrupt on Read multiple and Write multiple (16) | 8010 _H |
| 48 | Reserved | 0000 _H |
| 49 | Standard Standby timer, IORDY supported and may be disabled | 2F00 _H |
| 50 | ATA-reserved | 0000 _H |
| 51 | PIO data-transfer cycle timing mode | 0200 _H |
| 52 | Retired | 0200 _H |
| 53 | Words 54–58, 64–70 and 88 are valid | 0007 _H |
| 54 | Number of current logical cylinders | xxxx _H |
| 55 | Number of current logical heads | xxxx _H |

| Word | Description | Value |
|-------------|---------------------------------------------------------------------------------------------------------------------------------------------------------------------------------------------------------------------------------------------------------------------------------------------------------------------------------------------------------------------------------------------------------------------------------|-------------------------------------------------------------------------------|
| 56 | Number of current logical sectors per logical track | xxxx _H |
| 57–58 | Current capacity in sectors | xxxx _H |
| 59 | Number of sectors transferred during a Read Multiple or Write Multiple command | xxxx _H |
| 60–61 | Total number of user-addressable LBA sectors available (see Section 2.2 for related information) *Note: The maximum value allowed in this field is: 0FFFFFFFh (268,435,455 sectors, 137 Gbytes). Drives with capacities over 137 Gbytes will have 0FFFFFFFh in this field and the actual number of user-addressable LBAs specified in words 100-103. This is required for drives that support the 48-bit addressing feature. | 0FFFFFFFh* |
| 62 | Retired | 0000 _H |
| 63 | Multiword DMA active and modes supported (see note following this table) | xx07 _H |
| 64 | Advanced PIO modes supported (modes 3 and 4 supported) | 0003 _H |
| 65 | Minimum multiword DMA transfer cycle time per word (120 nsec) | 0078 _H |
| 66 | Recommended multiword DMA transfer cycle time per word (120 nsec) | 0078 _H |
| 67 | Minimum PIO cycle time without IORDY flow control (240 nsec) | 00F0 _H |
| 68 | Minimum PIO cycle time with IORDY flow control (120 nsec) | 0078 _H |
| 69–74 | ATA-reserved | 0000 _H |
| 75 | Queue depth | 0000 _H |
| 76 | Serial ATA capabilities | xxxx _H |
| 77 | Reserved for future Serial ATA definition | xxxx _H |
| 78 | Serial ATA features supported | xxxx _H |
| 79 | Serial ATA features enabled | xxxx _H |
| 80 | Major version number | 003E _H |
| 81 | Minor version number | 0000 _H |
| 82 | Command sets supported | 364B _H |
| 83 | Command sets supported | 7C03 _H |
| 84 | Command sets support extension (see note following this table) | 4003 _H See Word 108-111 note. (4003H = 0100000000000011 binary) |
| 85 | Command sets enabled | 30xx _H |
| 86 | Command sets enabled | 0001 _H |
| 87 | Command sets enable extension | 4000 _H |
| 88 | Ultra DMA support and current mode (see note following this table) | xx3F _H |
| 89 | Security erase time | 0000 _H |
| 90 | Enhanced security erase time | 0000 _H |
| 92 | Master password revision code | FFFE _H |
| 93 | Hardware reset value | xxxx _H |
| 95–99 | ATA-reserved | 0000 _H |

| Word | Description | Value |
|---------|------------------------------------------------------------------------------------------------------------------------------------------------------------------------------------------------------------------|-------------------------------------------------------------------------------------------|
| 100–103 | Total number of user-addressable LBA sectors available (see Section 2.2 for related information). These words are required for drives that support the 48-bit addressing feature. Maximum value: 0000FFFFFFFFFh. | 1000GB models = 1,953,525,168 500GB models = 976,773,168 250GB models = 488,397,168 |
| 104–107 | ATA-reserved | 0000 _H |
| 108–111 | The mandatory value of the world wide name (WWN) for the drive. NOTE: This field is valid if word 84, bit 8 is set to 1 indicating 64-bit WWN support. | Each drive will have a unique value. |
| 112–127 | ATA-reserved | 0000 _H |
| 128 | Security status | 0001 _H |
| 129–159 | Seagate-reserved | xxxx _H |
| 160–254 | ATA-reserved | 0000 _H |
| 255 | Integrity word | xxA5 _H |

Note. See the bit descriptions below for words 63, 84, and 88 of the Identify Drive data.

| Description (if bit is set to 1) | |
|----------------------------------|----------------------------------------------------------------------|
| | Word 63 |
| 0 | Multiword DMA mode 0 is supported. |
| 1 | Multiword DMA mode 1 is supported. |
| 2 | Multiword DMA mode 2 is supported. |
| 8 | Multiword DMA mode 0 is currently active. |
| 9 | Multiword DMA mode 1 is currently active. |
| 10 | Multiword DMA mode 2 is currently active. |
| | Word 84 |
| 0 | SMART error logging is supported. |
| 1 | SMART self-test is supported. |
| 2 | Media serial number is supported. |
| 3 | Media Card Pass Through Command feature set is supported. |
| 4 | Streaming feature set is supported. |
| 5 | GPL feature set is supported. |
| 6 | WRITE DMA FUA EXT and WRITE MULTIPLE FUA EXT commands are supported. |
| 7 | WRITE DMA QUEUED FUA EXT command is supported. |
| 8 | 64-bit World Wide Name is supported. |
| 9-10 | Obsolete. |
| 11-12 | Reserved for TLC. |
| 13 | IDLE IMMEDIATE command with IUNLOAD feature is supported. |
| 14 | Shall be set to 1. |
| 15 | Shall be cleared to 0. |
| | Word 88 |
| 0 | Ultra DMA mode 0 is supported. |

| | | |
|--|----|---------------------------------------|
| | 1 | Ultra DMA mode 1 is supported. |
| | 2 | Ultra DMA mode 2 is supported. |
| | 3 | Ultra DMA mode 3 is supported. |
| | 4 | Ultra DMA mode 4 is supported. |
| | 5 | Ultra DMA mode 5 is supported. |
| | 6 | Ultra DMA mode 6 is supported. |
| | 8 | Ultra DMA mode 0 is currently active. |
| | 9 | Ultra DMA mode 1 is currently active. |
| | 10 | Ultra DMA mode 2 is currently active. |
| | 11 | Ultra DMA mode 3 is currently active. |
| | 12 | Ultra DMA mode 4 is currently active. |
| | 13 | Ultra DMA mode 5 is currently active. |
| | 14 | Ultra DMA mode 6 is currently active. |

6.3.2 Set Features command

This command controls the implementation of various features that the drive supports. When the drive receives this command, it sets BSY, checks the contents of the Features register, clears BSY and generates an interrupt. If the value in the register does not represent a feature that the drive supports, the command is aborted. Power-on default has the read look-ahead and write caching features enabled. The acceptable values for the Features register are defined as follows:

Table 7: Set Features command values

| | |
|-----------------|-----------------------------------------------------------------------------------------------|
| 02 _H | Enable write cache (<i>default</i>). |
| 03 _H | Set transfer mode (based on value in Sector Count register). Sector Count register values: |
| 00 _H | Set PIO mode to default (PIO mode 2). |
| 01 _H | Set PIO mode to default and disable IORDY (PIO mode 2). |
| 08 _H | PIO mode 0 |
| 09 _H | PIO mode 1 |
| 0A _H | PIO mode 2 |
| 0B _H | PIO mode 3 |
| 0C _H | PIO mode 4 (<i>default</i>) |
| 20 _H | Multiword DMA mode 0 |
| 21 _H | Multiword DMA mode 1 |
| 22 _H | Multiword DMA mode 2 |
| 40 _H | Ultra DMA mode 0 |
| 41 _H | Ultra DMA mode 1 |
| 42 _H | Ultra DMA mode 2 |
| 43 _H | Ultra DMA mode 3 |
| 44 _H | Ultra DMA mode 4 |
| 45 _H | Ultra DMA mode 5 |
| 46 _H | Ultra DMA mode 6 |
| 10 _H | Enable use of SATA features |
| 55 _H | Disable read look-ahead (read cache) feature. |
| 82 _H | Disable write cache |
| 90 _H | Disable use of SATA features |
| AA _H | Enable read look-ahead (read cache) feature (<i>default</i>). |
| F1 _H | Report full capacity available |

Note. At power-on, or after a hardware or software reset, the default values of the features are as indicated above.

6.3.3 S.M.A.R.T. commands

S.M.A.R.T. provides near-term failure prediction for disc drives. When S.M.A.R.T. is enabled, the drive monitors predetermined drive attributes that are susceptible to degradation over time. If self-monitoring determines that a failure is likely, S.M.A.R.T. makes a status report available to the host. Not all failures are predictable. S.M.A.R.T. predictability is limited to the attributes the drive can monitor. For more information on S.M.A.R.T. commands and implementation, see the *Draft ATA-5 Standard*.

SeaTools diagnostic software activates a built-in drive self-test (DST S.M.A.R.T. command for D4_H) that eliminates unnecessary drive returns. The diagnostic software ships with all new drives and is also available at: <http://seatools.seagate.com>.

This drive is shipped with S.M.A.R.T. features disabled. You must have a recent BIOS or software package that supports S.M.A.R.T. to enable this feature. The table below shows the S.M.A.R.T. command codes that the drive uses.

Table 8: S.M.A.R.T. commands

| Code in features register | S.M.A.R.T. command |
|---------------------------|--------------------------------------------------|
| D0 _H | S.M.A.R.T. Read Data |
| D2 _H | S.M.A.R.T. Enable/Disable Attribute Autosave |
| D3 _H | S.M.A.R.T. Save Attribute Values |
| D4 _H | S.M.A.R.T. Execute Off-line Immediate (runs DST) |
| D5 _H | S.M.A.R.T. Read Log Sector |
| D6 _H | S.M.A.R.T. Write Log Sector |
| D8 _H | S.M.A.R.T. Enable Operations |
| D9 _H | S.M.A.R.T. Disable Operations |
| DA _H | S.M.A.R.T. Return Status |

Note. If an appropriate code is not written to the Features Register, the command is aborted and 0x04 (abort) is written to the Error register.



Seagate Technology LLC

AMERICAS Seagate Technology LLC 10200 South De Anza Boulevard, Cupertino, California 95014, United States, 408-658-1000

ASIA/PACIFIC Seagate Singapore International Headquarters Pte. Ltd. 7000 Ang Mo Kio Avenue 5, Singapore 569877, 65-6485-3888

EUROPE, MIDDLE EAST AND AFRICA Seagate Technology SAS 16-18 rue du Dôme, 92100 Boulogne-Billancourt, France, 33 1-4186 10 00

Publication Number: 100545983, Rev. G

April 2016